

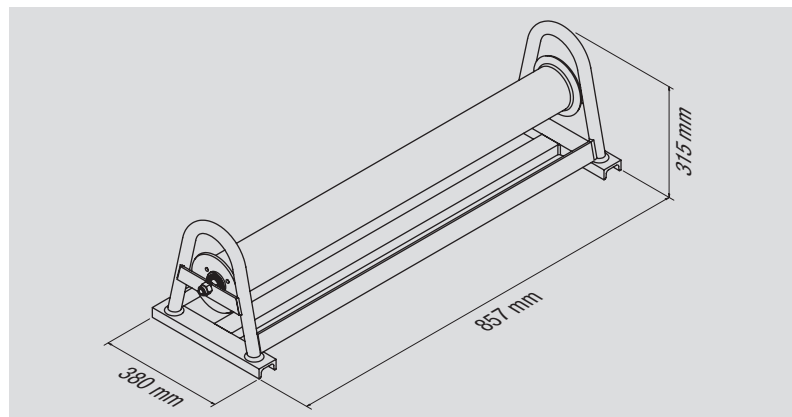

<p><b>EN</b></p> <p>Cable laying ground roller fit for installations cables with <b>ø 200 mm</b> max.</p> <p>Composed by:</p> <ul style="list-style-type: none"> <li>galvanized steel frame</li> <li>running roller made of <b>galvanized steel</b> mounted on shielded ball bearings</li> </ul>	<p><b>D</b></p> <p>Kabelverlegerolle zur geradlinigen Verlegung von Kabeln bis zu einem ø von <b>200 mm</b></p> <p>Bestehend aus:</p> <ul style="list-style-type: none"> <li>verzinkten Stahlrahmen</li> <li>Rolle aus <b>verzinktem Stahl</b>, gelagert mittels doppelt geschützter Kugellager</li> </ul>	<p><b>E</b></p> <p>Rodillo para colocar cables adecuado para la colocación en línea recta de cables con un ø máx. de <b>200 mm</b></p> <p>Compuesto de:</p> <ul style="list-style-type: none"> <li>bastidor en acero cincado</li> <li>rodillo de deslizamiento en <b>acero cincado</b> montado sobre cojinetes de esferas apantallados</li> </ul>	<p><b>F</b></p> <p>Galet de tirage de câbles convenant pour le tirage rectiligne de câbles du ø de <b>200 mm</b> max.</p> <p>Comprenant:</p> <ul style="list-style-type: none"> <li>un châssis en acier galvanisé</li> <li>un galet en <b>acier galvanisé</b> monté sur roulements à billes blindés</li> </ul>	<p><b>I</b></p> <p>Rullo posacavi adatto per la posa in rettilino di cavi fino al <b>ø 200 mm</b> max.</p> <p>Composto da:</p> <ul style="list-style-type: none"> <li>telaio in acciaio zincato</li> <li>rullo di scorrimento in <b>acciaio zincato</b> montato su cuscinetti a sfere schermati</li> </ul>
--	--	---	--	--

**Accessories • Zubehör • Accesorios • Accessoires • Accessori**

<p><b>[1]</b> Spare roller comes complete of screwed shaft M12, ball-bearings, nuts and bolts.</p>	<p><b>[1]</b> Ersatzrolle aus verzinktem Stahl, mit Gewindestift M12, Kugellager, Beilagscheiben und Mutter.</p>	<p><b>[1]</b> Rodillo de repuesto con perno roscado M12, cojinetes, arandelas y bulones.</p>	<p><b>[1]</b> Galet de rechange muni d'axe fileté M12, roulements, rondelles et boulons.</p>	<p><b>[1]</b> Rullo di ricambio, completo di perno filettato M12, cuscinetti, rondelle e bulloni.</p>
--	--	--	--	---

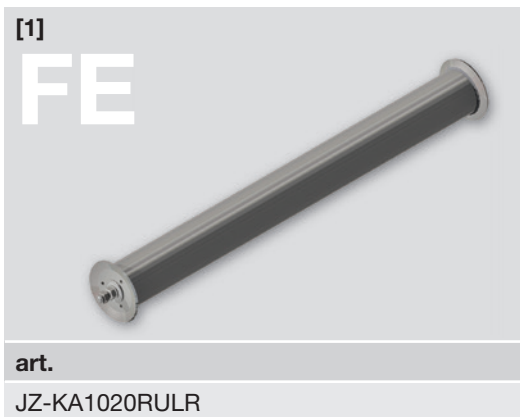

857 x 380 x 315 mm	17 kg	300 daN	ø 200 mm	ø 82 - 115 x 810 mm